

InGaAs APD Preamplifier Module



CMC Electronics' 264-339822 series use an InGaAs APD with low k-factor of 0.2, with a built-in preamplifier enabling optimum signal-to-noise performance.

The APD is coupled to a GaAs FET input trans-impedance amplifier in a 12-lead TO-8 package.

The internal temperature can be monitored via an embedded thermal sensor located close to the APD. The module is designed with a 50 Ω output impedance and can be AC- or DC-coupled.

Customizations such as bandwidth tuning, NEP screening, responsivity optimization and different temperature sensors are available upon request.

Features

- 80 – 200 μm InGaAs APD
- 100 – 200 MHz Preamplifier Module
- Spectral Response: 1050 – 1600 nm
- Low k-factor InGaAs APD
- Low Noise Equivalent Power (NEP)
- Hermetically Sealed TO-8 Package
- ITAR-Free
- ROHS compliant
- Optional:
 - Fast Overload Recovery Circuitry
 - Fiber Receptacle

Applications

- LiDAR and Laser Range Finding
- Instrumentation
- Free-Space Communications
- Industrial
- Photometry
- Distributed Fiber Optic Sensing (DFOS)
- Distributed Temperature Sensing (DTS)
- Distributed Acoustic Sensing (DAS)
- Structural Health Monitoring (SHM)

Table 1. Electro-Optical Characteristics

Unless otherwise specified: $T_{case} = 25\text{ °C}$, $V_{POS} = 5.0\text{ V}$, $V_{NEG} = -5.0\text{ V}$, $\lambda = 1570\text{ nm} \pm 10\text{ nm}$
(Externally AC coupled through $4.7\text{ }\mu\text{F}$)

Parameter	Min.	Typ.	Max.	Units
Operating Voltage, V_{OP} (Note 1)	40	54	85	V
Temperature coefficient of V_{OP}		0.07		V/°C
Responsivity		1.2		MV/W
Output impedance, R_{out}		50		Ω
Noise equivalent power (Note 2)				
Active diameter 80 μm		65	120	fW/ $\sqrt{\text{Hz}}$
Active diameter 200 μm		90	135	fW/ $\sqrt{\text{Hz}}$
Bandwidth, f_{-3dB}				
Active diameter 80 μm	180	200		MHz
Active diameter 200 μm	80	100		MHz
Rise time (10-90 %) & Fall time (90-10 %)				
Active diameter 80 μm		1.75		ns
Active diameter 200 μm		3.5		ns
Linear output voltage swing (Pulse)	0.75	1.25	2.0	V
Output offset voltage	-0.75	-0.45	0	V
Thermal sensor (1N914 diode) (Note 3)				
I_f of 5 mA at 25°C		645		mV
Sensor sensitivity		-1.9		mV/°C
Overload recovery for optical power input signal of 1 mW, 20 ns pulse width:				
$V_{out} \rightarrow 200\text{ ns}$ after pulse start			250	mV
$V_{out} \rightarrow 1\text{ }\mu\text{s}$ after pulse start			40	mV
Hybrid Supply current				
V_{POS} (pin 10)	25		35	mA
V_{NEG} (pin 11)	-20		-10	mA

- Notes:**
- Each APD receiver will have its individual V_{OP} (provided on its production tests report).
 - Integration of the noise calculation is based on f_{-3dB} bandwidth.
 - Alternate thermal sensors (thermistance or diode) are available upon request.

Table 2. Absolute-Maximum Ratings, Limiting Values

Parameter	Min.	Max.	Units
APD breakdown, Maximum voltage [$HV_{POSITIVE}$ (pin7)] (Note 1)		90	V
Recommended overcurrent limit		100	μA
Input Voltage Positive Supply [V_{POS} (+5V) (pin10)]	+4.8	+6.0	V
Input Voltage Negative Supply [V_{NEG} (-5V) (pin11)]	-4.8	-6.0	V
Maximum Optical Power, CW		10	μW
Peak value, 20ns pulses <100Hz		100	kW/cm ²
Temperature sensor (1N914 diode) fixed input current between			
Sensor V_{in} \rightarrow TSensor ANODE (pin 8)	1	10	mA
Sensor output \rightarrow TSensor CATHODE (pin 9)	1	10	mA
Operating Temperature	-40	85	°C
Storage Temperature	-55	125	°C
Soldering Temperature (5 s, leads only)		250	°C

Note: 1. Absolute maximum over the product Temperature Operating Range (-40°C to +85°C).

Figure 1. Typical Normalized Responsivity (M=1)

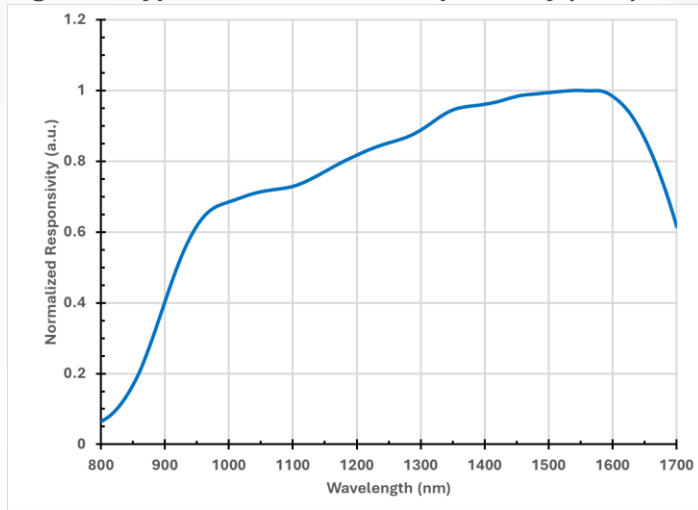

Figure 2. Typical Normalized Frequency Response

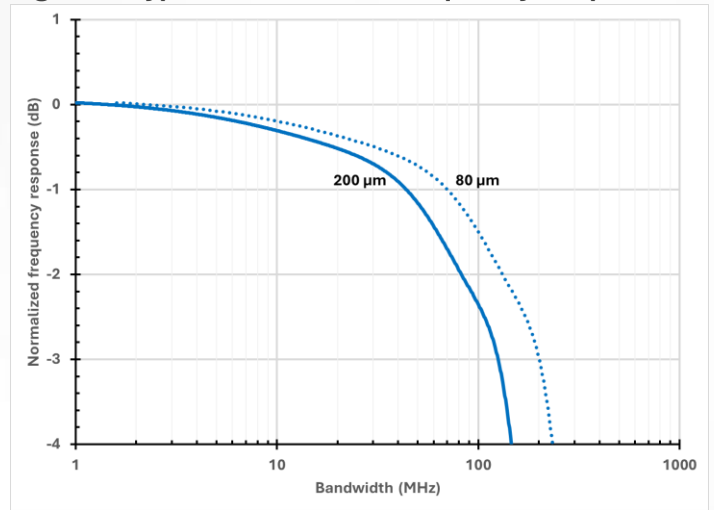

Figure 3. Typ. Responsivity, Diameter = 80 μm

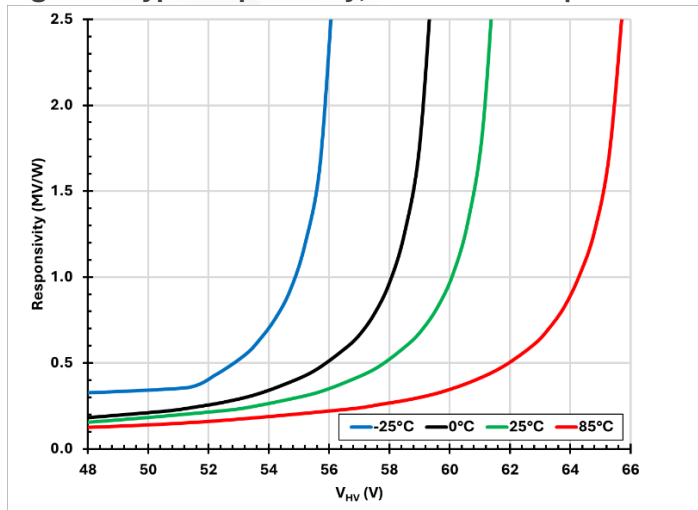

Figure 5. Typ. NEP, Diameter = 80 μm

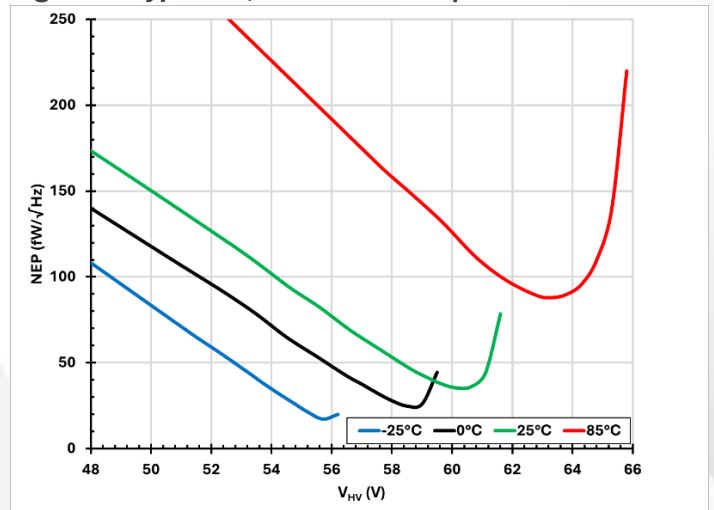

Figure 4. Typ. Responsivity, Diameter = 200 μm

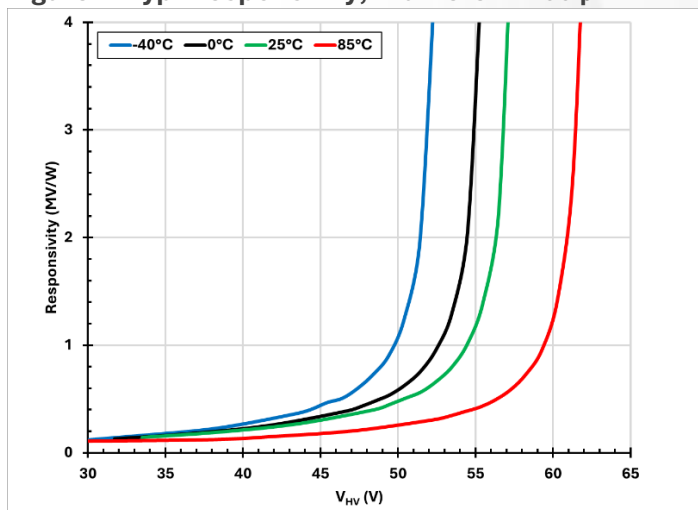
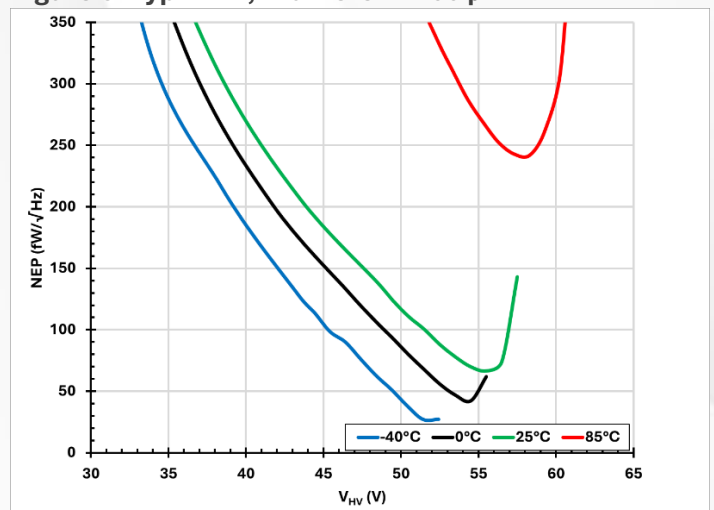

Figure 6. Typ. NEP, Diameter = 200 μm



264-339822 Series
 InGaAs Avalanche Photodiode Preamplifier Module
 Figure 7. Package Dimension and Pinout

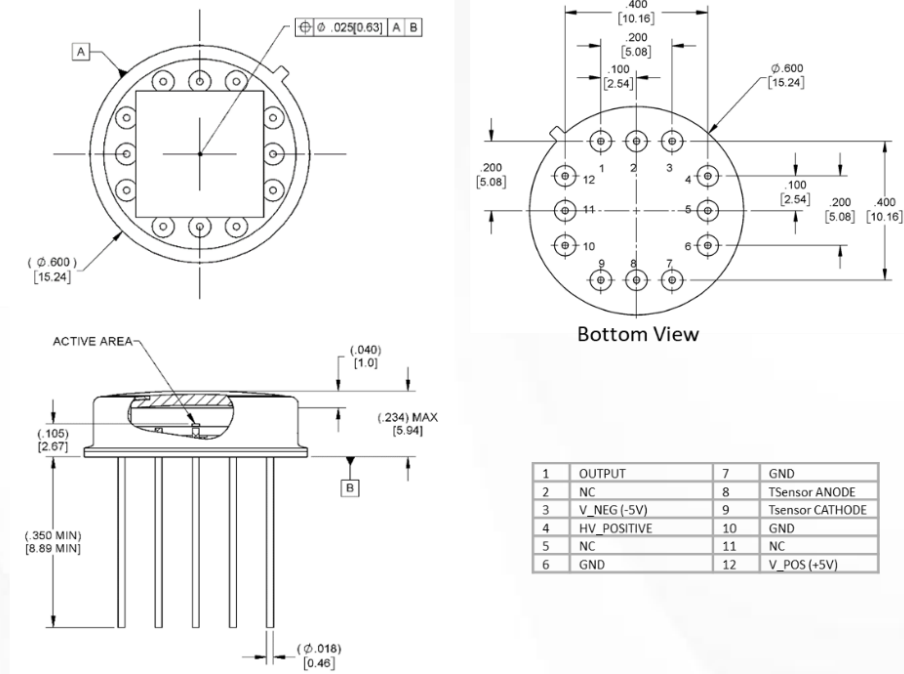

Figure 8. CMC 264-339822 Series block diagram

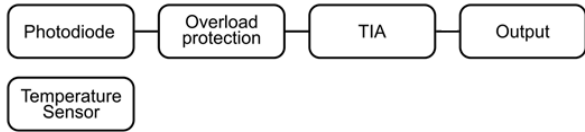
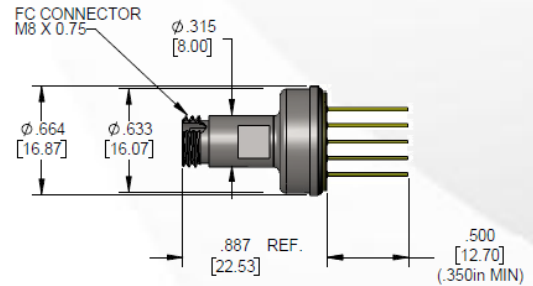

Figure 9. FC connector (617-339822)



Unless otherwise specified, dimensions are in inches [mm] and are for reference only.

Table 3. Ordering Guide

VAR	Typical Bandwidth	Active Diameter	Comments
264-339822-002	100 MHz	200 μ m	
617-339822-002			with FC connector
264-339822-003	200 MHz	80 μ m	
617-339822-003			with FC connector



For more information, visit www.cmcelectronics.ca/optoelectronics or email us at opto@cmcelectronics.ca

For information purposes only. To accommodate product improvements, specifications are subject to change without notice.

APPROVED FOR PUBLIC RELEASE; DISTRIBUTION IS UNLIMITED
 264-339822-VAR | Datasheet REV 04.2026