

Fiber Pigtailed InGaAs APD Preamplifier Module



CMC Electronics' 276-339832 series use an InGaAs APD with a low k-factor of 0.2, with a built-in preamplifier enabling optimum signal-to-noise performance.

The APD preamplifier receiver is housed in a robust 16-pin surface mount butterfly package with a 50 μm multimode (MM) graded-index core fiber.

The internal temperature can be monitored via an embedded thermal sensor. The module is designed with a 10 Ω output impedance and can be AC- or DC-coupled.

Customizations such as fiber diameter and type, bandwidth selection, NEP screening, different temperature sensors and further responsivity optimization are available upon request.

Features

- 120 MHz Preamplifier Module
- Spectral Response: 1050 – 1600nm
- Low k-factor InGaAs APD
- Low Noise Equivalent Power (NEP)
- 50 μm Multimode fiber pigtail
- High dynamic range
- Hermetically Sealed 16-pin package
- ITAR-Free
- ROHS compliant
- Optional:
 - Fast Overload Recovery Circuitry

Applications

- Range Finding
- LiDAR
- Instrumentation
- Distributed Temperature Sensing (DTS)
- Distributed Acoustic Sensing (DAS)
- Structural Health Monitoring (SHM)
- Free-Space Communications (FSO)

Table 1. Electro-Optical Characteristics**Conditions:** $T_{\text{case}} = 25^{\circ}\text{C}$, $V_{+} = 5.0\text{ V}$, $V_{-} = -5.0\text{ V}$, $V_{\text{HV}} = 40\text{ V}$ to V_{BR} , $V_{\text{OO_ADJ}} = -5\text{ V}$, $\lambda = 1570\text{ nm} \pm 20\text{ nm}$

Parameter	Min.	Typ.	Max.	Units
Operating Voltage, V_{OP} (Note 1)	40	54	85	V
Temperature coefficient of V_{OP}		0.07		V/ $^{\circ}\text{C}$
Responsivity		2.0		MV/W
Noise equivalent power (Note 2)		40		fW/ $\sqrt{\text{Hz}}$
Output impedance		10		Ω
Bandwidth, $f_{-3\text{dB}}$	100	120		MHz
Rise time (10-90 %) & Fall time (90-10 %)		3		ns
Linear output voltage swing (Pulse)	1.5	2.5	4.0	V
Output offset voltage	-0.75	-0.45	0	V
Thermal sensor (1N914 diode) (Note 3) I _r of 5 mA at 25°C Sensor sensitivity		645 -1.9		mV mV/ $^{\circ}\text{C}$
Overload recovery for optical power input signal: 1 mW, 20 ns pulse width: V _{out} → 200 ns after pulse start V _{out} → 1 μs after pulse start			250 40	mV mV
5 W, 20 ns pulse width (Note 4) (-001)		525		ns
5 W, 20 ns pulse width (Note 4) (-002)		325		ns
Hybrid Supply current V_POS (pin 10) V_NEG (pin 11)	25 -20		35 -10	mA mA

- Notes:**
- Each APD receiver will have its individual V_{OP} (provided on its production tests report).
 - Integration of the noise calculation is based on $f_{-3\text{dB}}$ bandwidth.
 - Alternate thermal sensors (thermistance or diode) are available upon request.
 - Not tested on all units

Table 2. Absolute-Maximum Ratings, Limiting Values

Parameter	Min.	Max.	Units
APD breakdown, Maximum voltage [HV_POS (pin 4)]		105	V
Recommended overcurrent limit		100	μA
Photodiode Total Current (All temp.)		1	mA
Input Voltage Positive Supply [V_POS (+5V) (pin 7)]		6	V
Input Voltage Negative Supply [V_NEG (-5V) (pin 5)]		6	V
Maximum Optical Power, CW		10	μW
Peak value, 20 ns pulses < 100 Hz		100	kW/cm ²
Temperature sensor fixed input current between Sensor V _{in} → TSensor ANODE (pin 8) Sensor output → TSensor CATHODE (pin 9)	1	10	mA
Operating Temperature	-40	85	$^{\circ}\text{C}$
Storage Temperature	-55	125	$^{\circ}\text{C}$
Soldering Temperature (5 s, leads only)		250	$^{\circ}\text{C}$

Figure 1. Typical Normalized Responsivity (M=1)

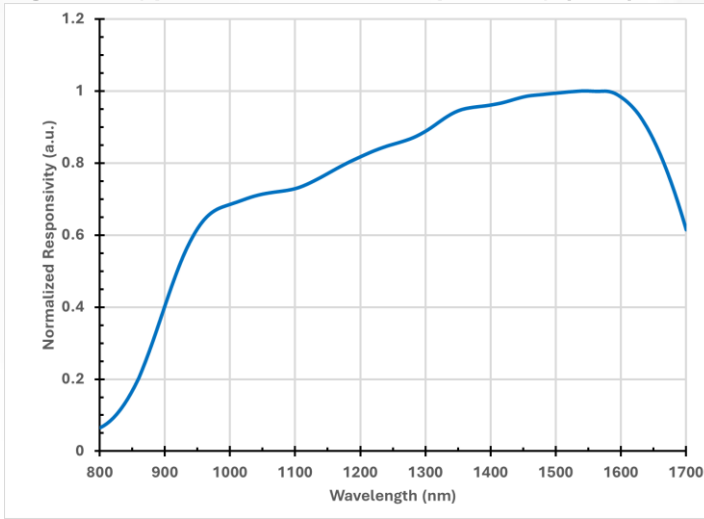

Figure 2. Typical Normalized Frequency Response

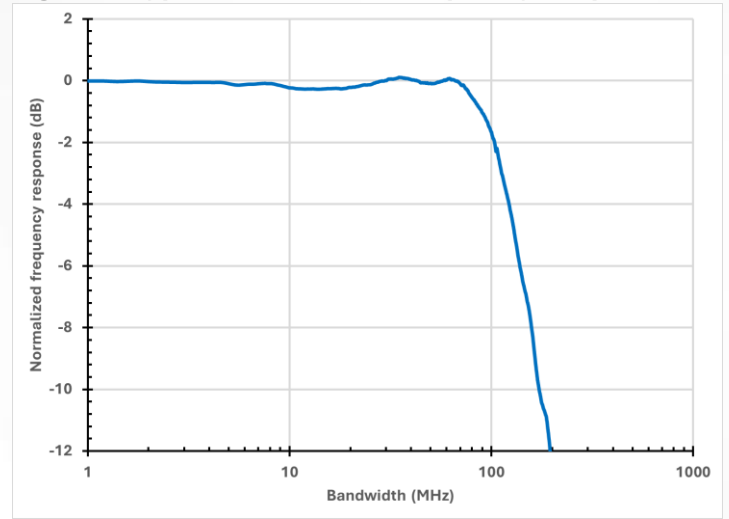

Figure 3. Typical Responsivity

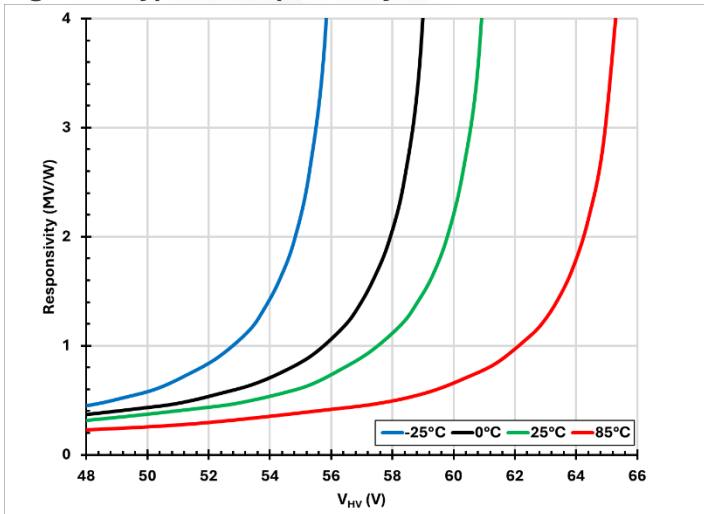

Figure 4. Typical Noise equivalent power

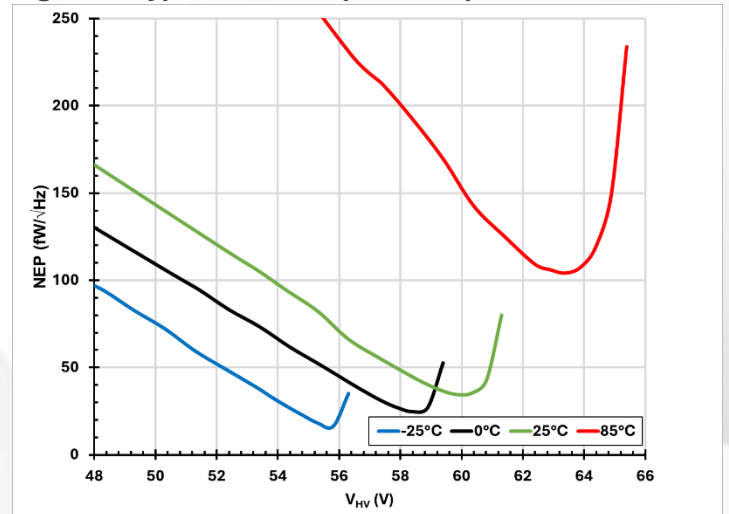

Figure 5. CMC 276-339832 Series block diagram

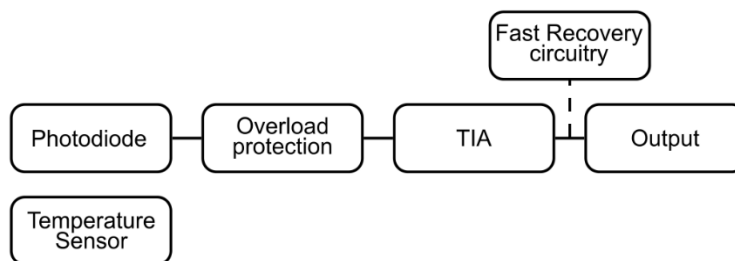
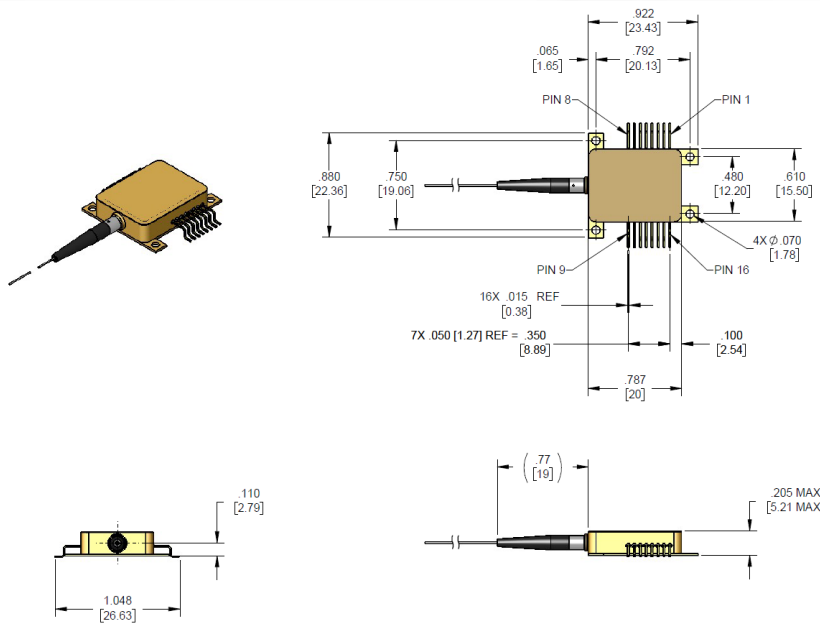

Figure 6. Package Dimension and Pinout

Unless otherwise specified, dimensions are in inches [mm] and are for reference only.



1	GND
2	TSensor ANODE
3	TSensor CATHODE
4	NC
5	V_NEG (-5V)
6	GND
7	V_POS (+5V)
8	GND
9	HV_POSITIVE
10	GND
11	GND
12	GND
13	OUTPUT
14	GND
15	VOO_ADJ
16	GND

Table 3. Ordering Guide

VAR	Typical Bandwidth	Comments
276-339832-001	120 MHz	Standard recovery
276-339832-002	120 MHz	Fast recovery from high power pulse



For more information, visit www.cmcelectronics.ca/optoelectronics
 or email us at opto@cmcelectronics.ca

For information purposes only. To accommodate product improvements, specifications are subject to change without notice.

APPROVED FOR PUBLIC RELEASE; DISTRIBUTION IS UNLIMITED
 276-339832-VAR | Datasheet REV 04.2026